

GPN

AGITATOR PUMP



“Pursuing close communication between people and water”

Tsurumi Manufacturing Company, Limited was founded in Osaka, Japan in 1924. Since the foundation, Tsurumi has consistently devoted its efforts to the creation and development of advanced water utilization technologies. Tsurumi has also innovated the pump manufacturing technologies in a constant pursuit of new opportunities and new fields that contribute to the advancement of our society and environment. This effort epitomizes its management policy “Dedicated to pursuing close communication between people and water through innovative creation and respect for harmony with nature.”

Amenics launched by **TSURUMI PUMP** is a Tsurumi-original keyword created from the combination of amenity and -ics which is a postfix used in academics and technology. This message expresses our pursuit of technology that is friendly to people and the Earth.

A production base boasting industry-leading scale and advanced facilities

Kyoto Plant

- Manufactures compact, super-sized, and special-purpose pumps.
- Designed for flexible operation. Follows a high-mix, low-volume approach to production. All processes are centrally computer-controlled.
- Features a vast tank with a maximum water depth of 11.7 meters and a maximum volume of 4,500 cubic meters of retained water. Includes an experimental tower rising 44 meters above ground.

Lot area: 46,000 square meters Total floor area: 30,000 square meters



FS57208 / ISO9001

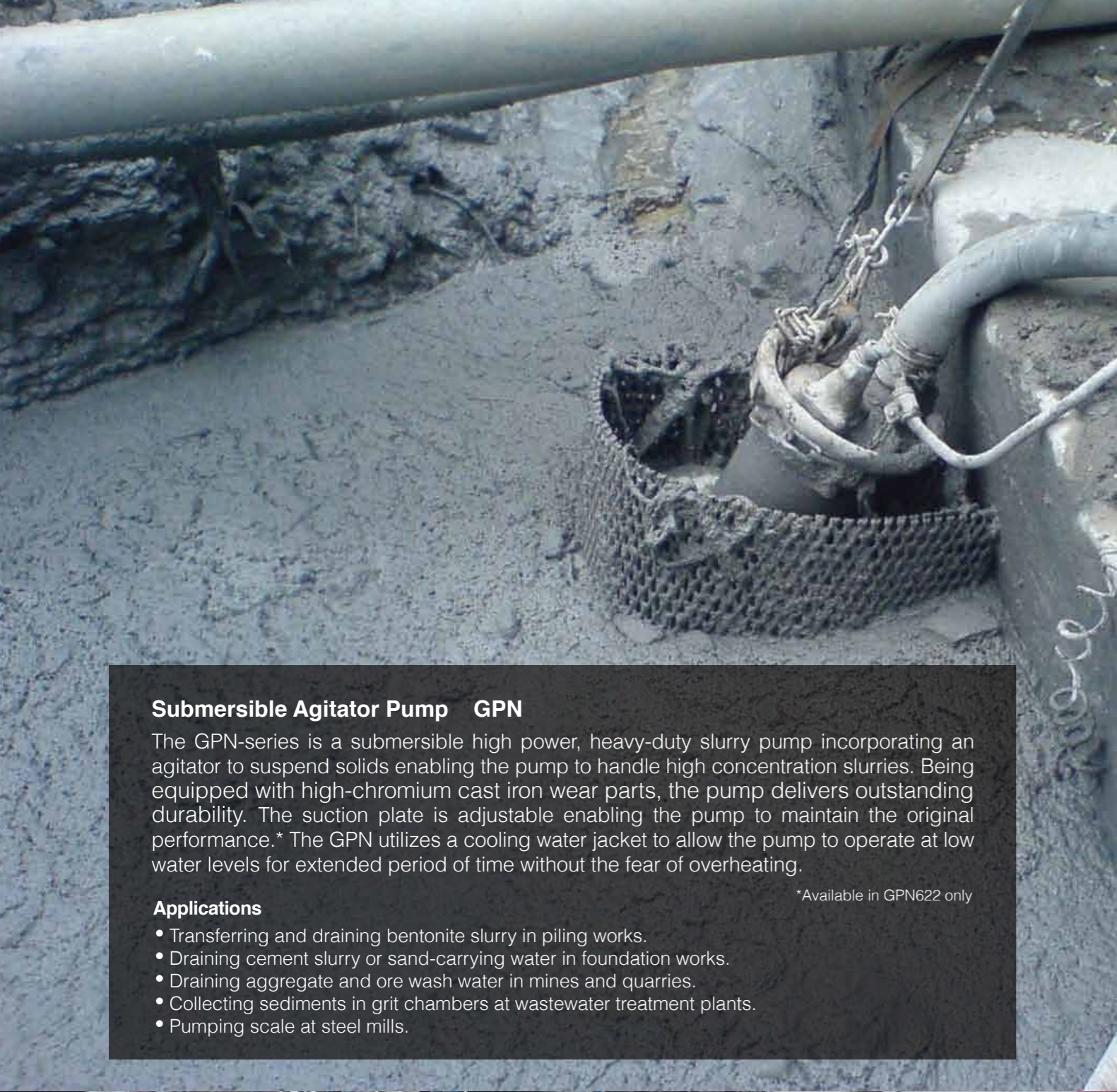

Submersible Agitator Pump GPN

The GPN-series is a submersible high power, heavy-duty slurry pump incorporating an agitator to suspend solids enabling the pump to handle high concentration slurries. Being equipped with high-chromium cast iron wear parts, the pump delivers outstanding durability. The suction plate is adjustable enabling the pump to maintain the original performance.* The GPN utilizes a cooling water jacket to allow the pump to operate at low water levels for extended period of time without the fear of overheating.

Applications

- Transferring and draining bentonite slurry in piling works.
- Draining cement slurry or sand-carrying water in foundation works.
- Draining aggregate and ore wash water in mines and quarries.
- Collecting sediments in grit chambers at wastewater treatment plants.
- Pumping scale at steel mills.

*Available in GPN622 only



Spiral Design with Water Jacket

The side discharge, spiral design allows smoother passage of the sucked solid matters. The motor is cooled by a water jacket assuring efficient motor cooling even when the pump operates with its motor exposed in air.

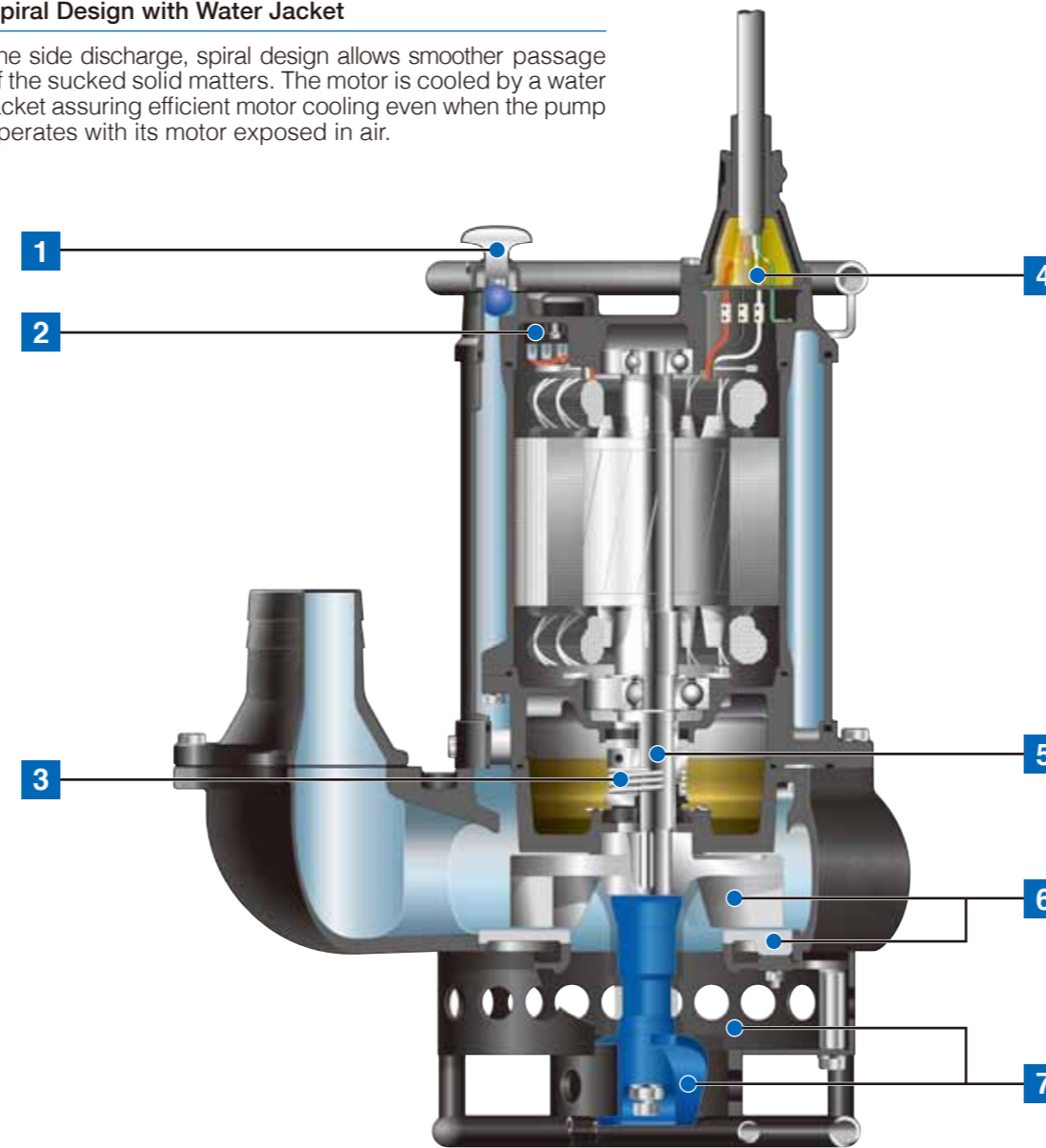

1 Air Release Valve

Fitted on the water jacket, it prevents the Air-lock. When air goes through the valve, the ball stays at the bottom, but when the pumped water starts to flow, it closes the outlet by its buoyancy.

2 Circle Thermal Protector

Detects both excess heat and excess amperage draw. It therefore protects against, overheating, overcurrent and dry-running.
*GPN622 has built-in miniature thermal protectors working with a dedicated circuit in the control panel.

3 Internal Mechanical Seal with Silicon Carbide Faces

Runs in the oil chamber, a clean, non-corrosive and abrasion free lubricating environment. It eliminates the problems like spring failure and ensures the longest operational life of any seal available.
*GPN622 has the Oil Lifter forcibly lubricating and cooling the mechanical seal.

4 Anti-wicking Cable Entry

Prevents water incursion due to capillary wicking should the power cable be damaged or the end submerged.

5 Chromium Molybdenum Motor Shaft

Made of SCM435 (JIS), chromium molybdenum steel (tensile strength 930 N/mm² and over). It has the superior performance against a shock given at the instant of sucking hard foreign matters.

6 High-chromium Iron Impeller & Suction Plate

Made of high-chromium cast iron ensuring highest durability. Even if the performance drops due to wearing out of the impeller and/or suction plate, it can be improved by simply replacing the suction plate.
*GPN622 has an adjustable suction plate.

7 Agitating Mechanism

Consists of a shaft-mounted agitator and a dedicated strainer. The agitator made of high-chromium cast iron resists wear caused by abrasive particles, and it suspends solids to assist in pumping sediments in combination with the strainer.

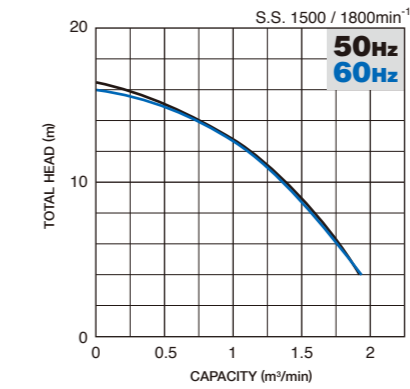

GPN35.5 (GPN3-80)

Motor Output	5.5 kW [Three-phase]
Dis. Bore	80 mm
Dis. Connection	Hose Coupling
Weight [excl. Cable]	145 kg
Cable Length	8 m
Motor Protector	Circle Thermal Protector
Starting Method	Direct on Line

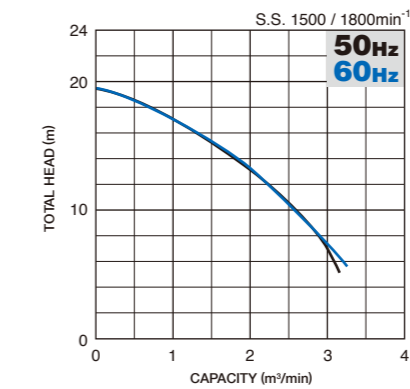
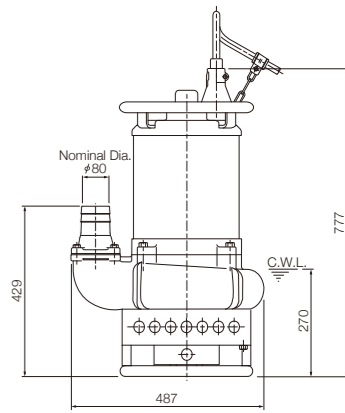

GPN411 (GPN3-100)

Motor Output	11 kW [Three-phase]
Dis. Bore	100 mm
Dis. Connection	Hose Coupling
Weight [excl. Cable]	217 kg
Cable Length	8 m
Motor Protector	Circle Thermal Protector
Starting Method	Direct on Line

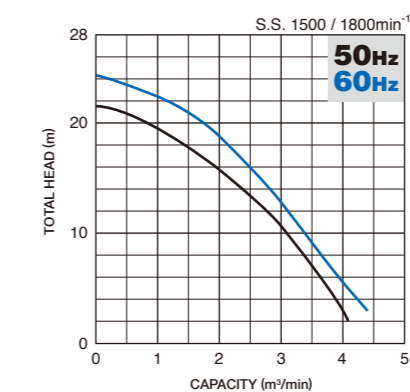
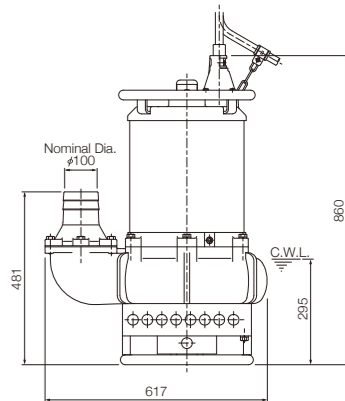

GPN415

Motor Output	15 kW [Three-phase]
Dis. Bore	100 mm
Dis. Connection	Hose Coupling
Weight [excl. Cable]	220 kg
Cable Length	10 m
Motor Protector	Circle Thermal Protector
Starting Method	Direct on Line

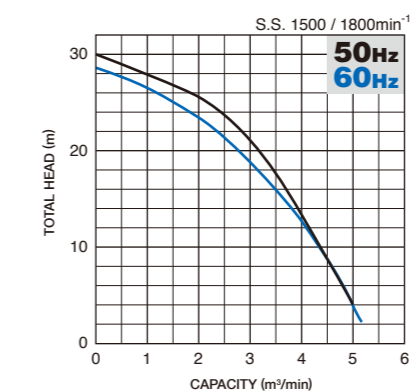
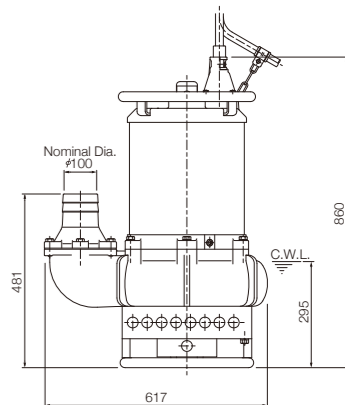

GPN622

Motor Output	22 kW [Three-phase]
Dis. Bore	150 mm
Dis. Connection	Hose Coupling
Weight [excl. Cable]	415 kg
Cable Length	10 m
Shaft Seal	Double Mechanical Seal with Oil Lifter
Motor Protector	Miniature Thermal Protector
Starting Method	Direct on Line

Leakage Sensor available as option

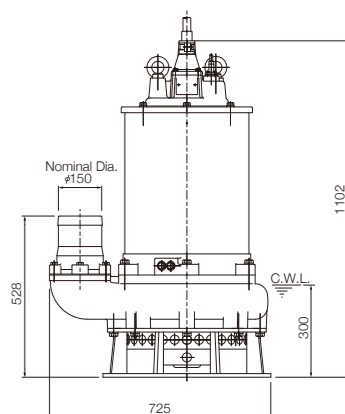



We reserve the right to change the specifications and designs for improvement without prior notice.

**TSURUMI
MANUFACTURING CO., LTD.**

Your Dealer



PRECISION

P U M P S

&

E N G I N E E R I N G

Printed in Japan CAT. IB108-A HB-F-B-R